



VIVA® Dual Access Animal Containment Workstation, Model VDA-4A\_



VIVA® Universal Animal Containment Workstation, Model VA2-4S\_G4 12"



VIVA® Bedding Disposal Animal Containment Workstation, Model VBD-4A\_

## VIVA® Animal Research Workstations

*The Portable Safety Solution for Animal Research Laboratories*

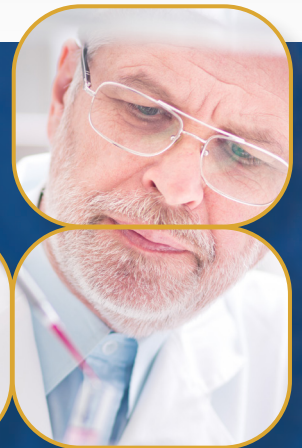



## Airflow Sensor

- Real-time airflow monitoring system
- Alerts the user if the airflow is insufficient

## Sentinel™ Gold Microprocessor Controller

- Displays all safety information on one screen
- Centered and angled down for an easy reach & viewing
- Selectable quickstart mode for fast operation



## Easy-to-clean Work Surface and Drain pan

- Two-piece, easy-to-lift stainless steel tray
- Drain hole on both sides to dump animal bedding



## Easy Work Access

- Large access opening of 344 mm (14")
- Accommodates rat and mouse cages
- Hinged up for easy cleaning



## Advanced Work Tray Design

- V-shaped grill to avoid blocking
- Center grill to separate clean and contaminated area
- Large tray handle for easy lifting



## Comfortable Leg Room

- 254 mm (10") leg room on both sides
- Reduces user's fatigue when in sitting position
- Hydraulic motor to adjust the height

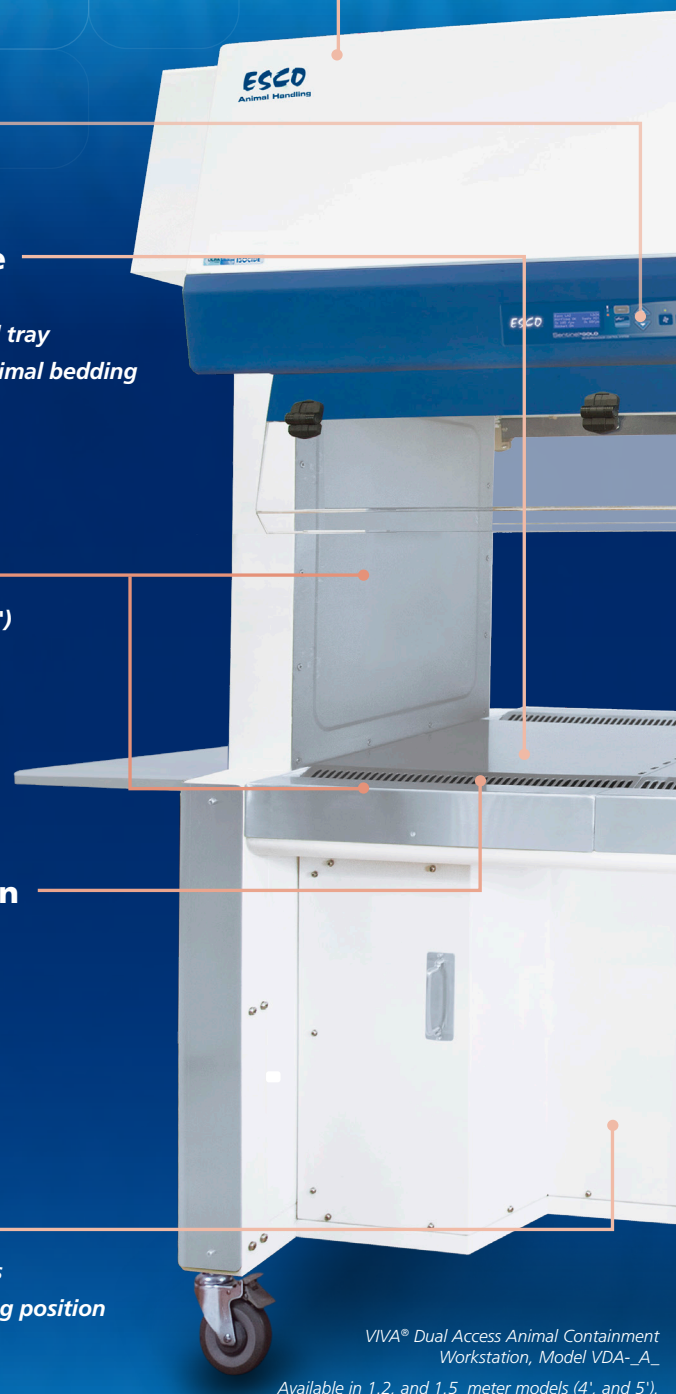

VIVA® Dual Access Animal Containment Workstation, Model VDA-\_A\_ Available in 1.2, and 1.5 meter models (4', and 5').

## Accessories and Options

Contact Esco or your Esco Sales Representative for details.

- Electrical Outlets
- Feed Hopper
- Foldable Side Tray
- Service Fixtures
- Side Shield



Side Shield



Feed Hopper

**VIVA.**

Animal Research Workstations • Dual Access Animal Transfer Containment Workstation

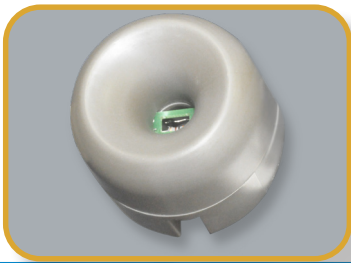

## ELISA Proven Containment

- Provides >99% allergen containment to ensure user's safety



### ULPA Filter

- 10x filtration efficiency than of HEPA filter
- Creates an ISO Class 3 work-zone instead of the industry-standard ISO Class 5

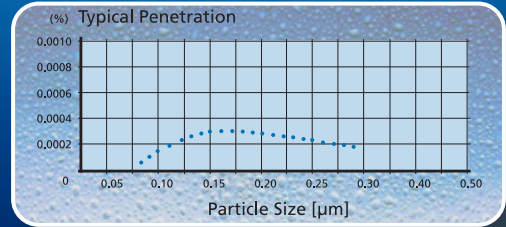

### Quiet Operation

- Comfortable low noise emission at 53 for the users and animals



### Isocide™ Antimicrobial Coating

- Silver-ion impregnated powder coat
- Inhibits the microbial growth to improve safety

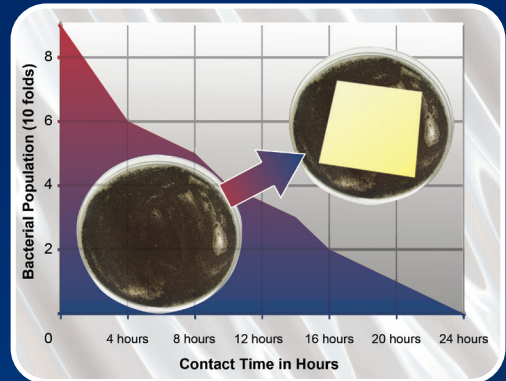

### Dual Energy-efficient DC ECM Blower

- Powered by the latest generation DC ECM that is more efficient than legacy ECM and VFD motors
- 70% Energy savings compared to AC motor
- Stable airflow despite building voltage fluctuations & filter loading

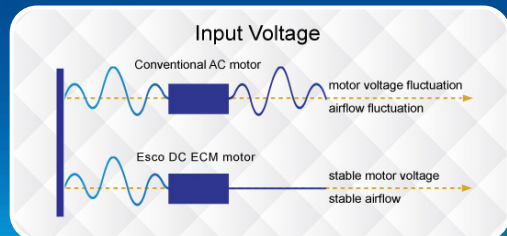

	Air Quality	Filtration	Electrical Safety
Standards Compliance	ISO 14644.1, Class 3, Worldwide JIS B9920, Class 3, Japan JIS BS5295, Class 3, Japan US Fed Std 209E, Class 1 USA	EN-1822 (H14), Europe IEST-RP-CC001.3, USA IEST-RP-CC007, USA IEST-RP-CC034.1, USA	UL-61010A-1, USA CSA22.2, No.1010-192, Canada EN61010-1, Europe IEC61010-1, International

# VIVA® G4 (VA2 G4) CLASS II TYPE A2 ANIMAL BSC,

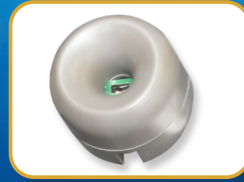

## Airflow Sensor

- Monitors real-time airflow for safety
- Alerts the user if airflow is insufficient

## USB Port and Zero Volt Relay Contact

- USB Port to send operational information to Building Management System (BMS)
- Zero Volt Relay Contact to turn ON/OFF exhaust blower and signal the building alarm



## Centurion 7" Capacitive Touchscreen Controller

- Displays all safety information on one large screen
- Shows cabinet parameters with intuitive 3D illustration
- Easy to use menu, similar to Smart Phone Apps
- Large buttons, easy to operate when wearing gloves
- Self-guidance to users to deal with specific situations
- Centered and angled down for easy reach and viewing



## Single Piece Wall

- Easy to reach service fixtures and electrical outlets on sidewalls
- Large radius corners for easy cleaning



## User-friendly Work Tray

- Largest useable area in the market
- Recessed to contain spillage
- Sloped perimeter for easy cleaning
- Large, easy to clean tray handle



## Raised Arm Rest

- Prevent grille blocking
- Comfortable working posture
- Durable stainless steel construction



## Ergonomic Work Zone

- 10° angle to optimize user comfort, reduce glare, and maximize reach into the work area
- Brightly illuminated with 1000 lux (93 ft-c)
- Industry-leading dimmable LED for optimum work comfort
- Airtight seal port for cable/tube exit protected by a negative pressure side wall
- 12" sash working height for mouse and rat cages



Available in 1.2, 1.5, and 1.8 meter models (4', 5', and 6').

## Pre-filter Rack

- Captures animal dander
- Easy to replace pre-filter
- Prolongs ULPA filter life



**VIVA.**

Lab Animal Research Products • Animal Workstation

# FEATURING ADVANCED TOUCHSCREEN CONTROLLER

## Energy-efficient DC ECM Blower

- The leading energy-efficient Class II Type A2 Biosafety Cabinet in the world with 70% energy savings compared to AC motor
- Stable airflow despite building voltage fluctuations and filter loading
- Standby mode to further reduce power consumption by 80%

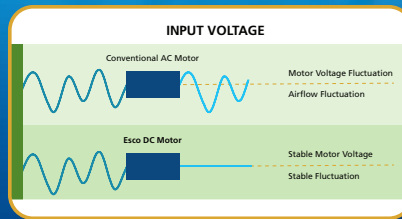

## Advanced ULPA Filtration System

- 10x Filtration efficiency of HEPA filter
- Creates ISO Class 3 work zone instead of industry-standard ISO Class 5
- Same 10 years filter life and replacement cost as HEPA filters

Note:

- 99.999% at 0.1 to 0.3 micron, ULPA as per IEST-RP-CC001.3 USA
- 99.999% at MPPS, H14 as per EN 1822 EU



## Dimmable LED Lamp

- Save energy and optimize work comfort



## Removable Paper Catch

- Prevent objects from being pulled into blower plenum
- Removable for easy cleaning



## Tray Support Beams

- Support work tray evenly for less vibration
- Cleaning holder to easily wipe the drain pan

## Isocide™ Powder Coat

- Silver-ion impregnated powder coat
- Inhibits microbial growth to improve safety
- Prevents the plenum from becoming biohazard landfill

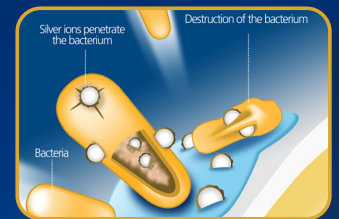

## ELISA Proven Containment

- Provides >99% allergen containment.
- Ensures user's safety



5

## Certification

	Performance	Air Quality	Filtration	Electrical Safety
Standards Compliance	NSF / ANSI 49, USA*	ISO 14644.1, Class 3, Worldwide US Fed Std 209E, Class 1 USA JIS B9920, Class 3, Japan	EN-1822 (H14), Europe IEST-RP-CC001, USA	UL 61010-1 3rd Ed, USA CSA22.2, No.1010-192, Canada IEC61010-1, Worldwide

\* The NSF / ANSI 49 certified models are VA2-4S\_ G4 and VA2-6S\_ G4

## Dynamic Chamber™

- Blower plenum and side walls are surrounded by negative pressure
- Prevent contaminants from escaping outside

- Positive Pressure
- Negative Pressure

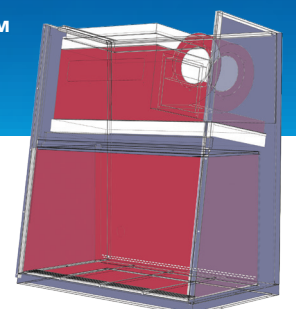



### Sentinel™ Silver Microprocessor Controller

- Displays all safety information on one screen
- Centered and angled down for easy reach & viewing

### Airflow Sensor

- Real-time airflow monitoring system
- Alerts the user if the airflow is insufficient

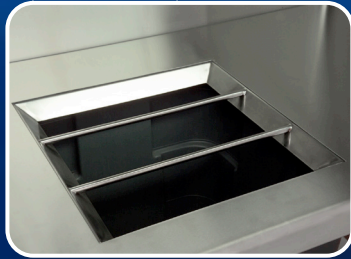

### Bang Bars

- Increases efficiency of bedding disposal operations



### Integrated Waste Chute

- Disposes refuse bag safely within the work-zone

6



VIVA® Bedding Disposal Animal Containment Workstation, Model VBD-4A\_

Available in 1.2 meter model (4') only.

#### User and Environment Protection

The VIVA Bedding Disposal Workstation provides operator and environment protection User animal allergen.

#### Exclusive hydraulic height-adjustable stand

Allows the work surface height to be adjusted to user preference, therefore minimizing strain during repetitive operations.

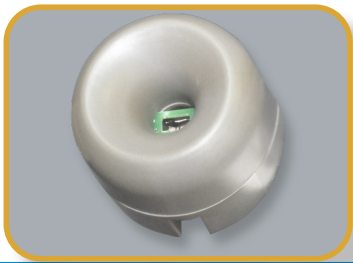

### Carbon Filter

- Nanocarb activated carbon filter to remove unpleasant odors



### ULPA Filter

- 10x filtration efficiency than of HEPA filter
- Creates an ISO Class 3 work-zone instead of the industry-standard ISO Class 5

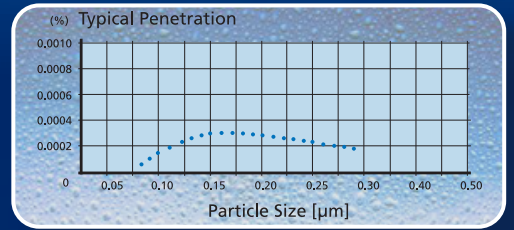

### ELISA-proven Containment

- Provides >99% allergen containment to ensure user's safety



### Isocide™ Antimicrobial Coating

- Silver-ion impregnated powder coat
- Inhibits the microbial growth to improve safety

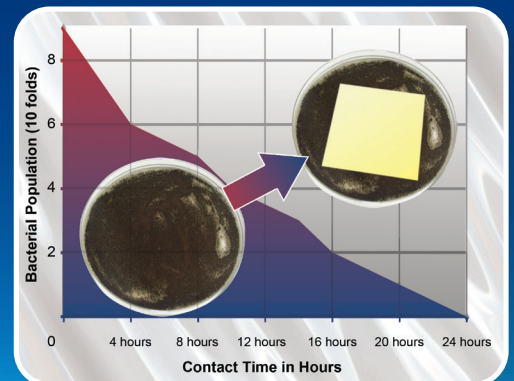

VIVA®

Standards Compliance	Filtration	Electrical Safety
	EN-1822 (H14), Europe IEST-RP-CC001.3, USA IEST-RP-CC007, USA IEST-RP-CC034.1, USA	UL61010-1, USA

# AIRFLOW PATTERN

## VDA Cabinet Airflow System

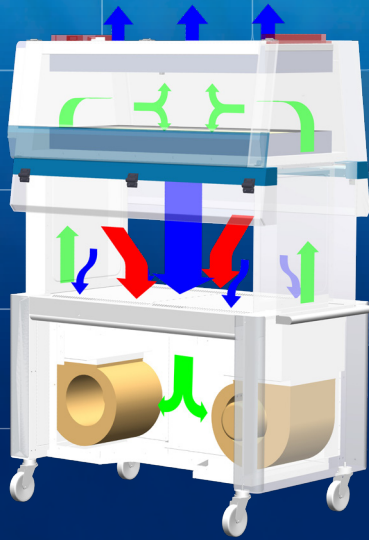

- The VDA Dual Access Workstation employs a recirculating airflow configuration for better filtration efficiency.
- The blower system pulls ambient intake air through the front grilles, creating inflow that provides operator protection from allergen inside the work-zone. An activated carbon pre-filter removes unpleasant odors
- Air flows through the common plenum on top of the cabinet. A portion of it goes up through ULPA filter as exhaust to create inflow. The remaining portion goes down

- ULPA-filtered air
- Unfiltered / Potentially contaminated air
- Room air / Inflow air

through ULPA supply filter and bathes the work-zone in clean laminar air with a non-turbulent downflow.

- The combination of vertical laminar inflow and downflow creates an air curtain to protect the user from contaminants released from the work surface.

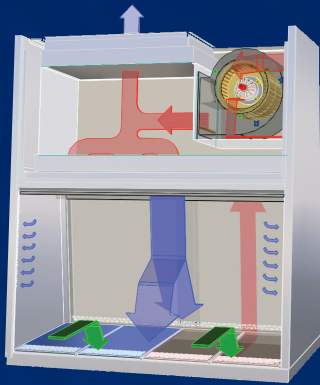

## VA2 Cabinet Airflow System

- Ambient air pulled through the perforations towards the work-zone front prevents contamination of the work surface and work product. The inflow does not mix with the clean air within the cabinet work-zone. Inflow air travels through a return path towards the common air plenum (blower plenum) at the top of the cabinet.
- Approximately 40% of the air in the common plenum is exhausted through the ULPA filter to the room. The remaining 60% of the air is passed through the downflow ULPA filter and into the work area as a vertical laminar flow air stream bathing the work surface in clean air.

- ULPA-filtered air
- Unfiltered / Potentially contaminated air
- Room air / Inflow air

- The uniform, non-turbulent air stream protects against cross-contamination within and throughout the work area.

- Near the work surface, the ULPA-filtered downflow air stream splits with a portion moving toward the front air grille, and the remainder moving to the rear air grille. A small portion of the downflow enters the side capture zones at a higher velocity (small blue arrows).

- A combination of inflow and downflow air streams form an air barrier that prevents contaminated room air from entering the work-zone, and prevents work surface emissions from escaping the work-zone.

## VBD Cabinet Airflow System

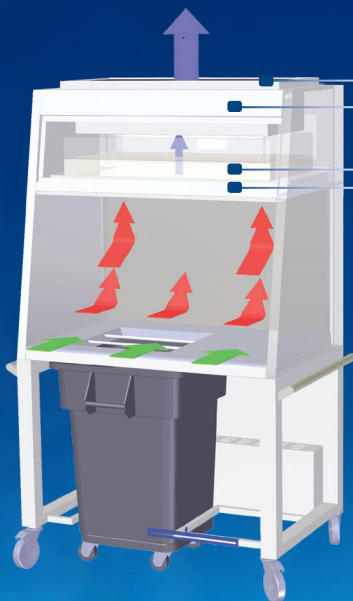

- Carbon Filter
- Blower
- Exhaust ULPA Filter
- Pre-filter

- Room air is drawn in across the front of the cabinet with an average velocity of 0.35 m/s (70 fpm).
- Air is drawn up through the cabinet's work-zone and forced through the ULPA filter (>99.999% typical efficiency for 0.1 to 0.3 micron sized particles).

- ULPA-filtered air
- Unfiltered / Potentially contaminated air
- Room air / Inflow air

- The full work-zone ceiling extraction system ensures airflow uniformity throughout the cabinet's main chamber.

- The ULPA filtered air then returns to the laboratory stripped of all airborne contaminants and odor.



## General Specifications, Dual Access Animal Containment Workstation, Model VDA

Model	VDA-4A_	VDA-5A_
External Dimensions (W x D x H)	1340 x 762 x 1961 mm (52.8" x 30.0" x 77.2") min height 1340 x 762 x 2245 mm (52.8" x 30.0" x 88.4") max height	1645 x 762 x 1961 mm (64.7" x 30.0" x 77.2") min height 1645 x 762 x 2245 mm (64.7" x 30.0" x 88.4") max height
Internal Work Area (W x D x H)	1100 x 465 x 564 mm (43.3" x 18.3" x 22.2")	1405 x 465 x 564 mm (55.3" x 18.3" x 22.2")
Downflow Velocity	0.24 m/s (47 fpm)	
Pre-Filter	Disposable and non-washable polyester fibres with 85% arrestence / EU3 rated	
ULPA Filter Typical Efficiency	>99.999% for particle size between 0.1 to 0.3 microns, per IEST-RP-CC001.3	
Sound Emission per EN 12469*	53 dBA	54 dBA
LED Lamp Intensity at Zero Ambient	1725 lux (160 foot candles)	1525 lux (142 foot candles)
Construction, Main Body	1.5 mm (0.06") 16 gauge EG Steel with Isocide™ Oven-Baked Epoxy-Polyester Powder Coated Finish	
Shipping Dimensions, Maximum (W x D x H)	1720 x 820 x 2240 mm (67.7" x 32.2" x 88.1")	2025 x 820 x 2240 mm (79.7" x 32.2" x 88.1")
Shipping Weight	342 Kg (754 lbs)	432 Kg (952 lbs)
Shipping Volume, Maximum	3.16 m <sup>3</sup> (111.6 cu.ft.)	3.72 m <sup>3</sup> (131.4 cu.ft.)
Electrical Rating	VDA-_A8	220-240 VAC, 50 / 60 Hz, 1Ø
	VDA-_A9	110-130 VAC, 50 / 60 Hz, 1Ø
Power Consumption	VDA-_A8	190 W
	VDA-_A9	210 W
Accessories	Foldable Side Tray (SS Shelf Kit)	VDA-001 5170257
	Side Shield	VDA-004 5170562
	Feed Hopper	VDA-006 5170594

\* Noise as measured in an open field / anechoic chamber.

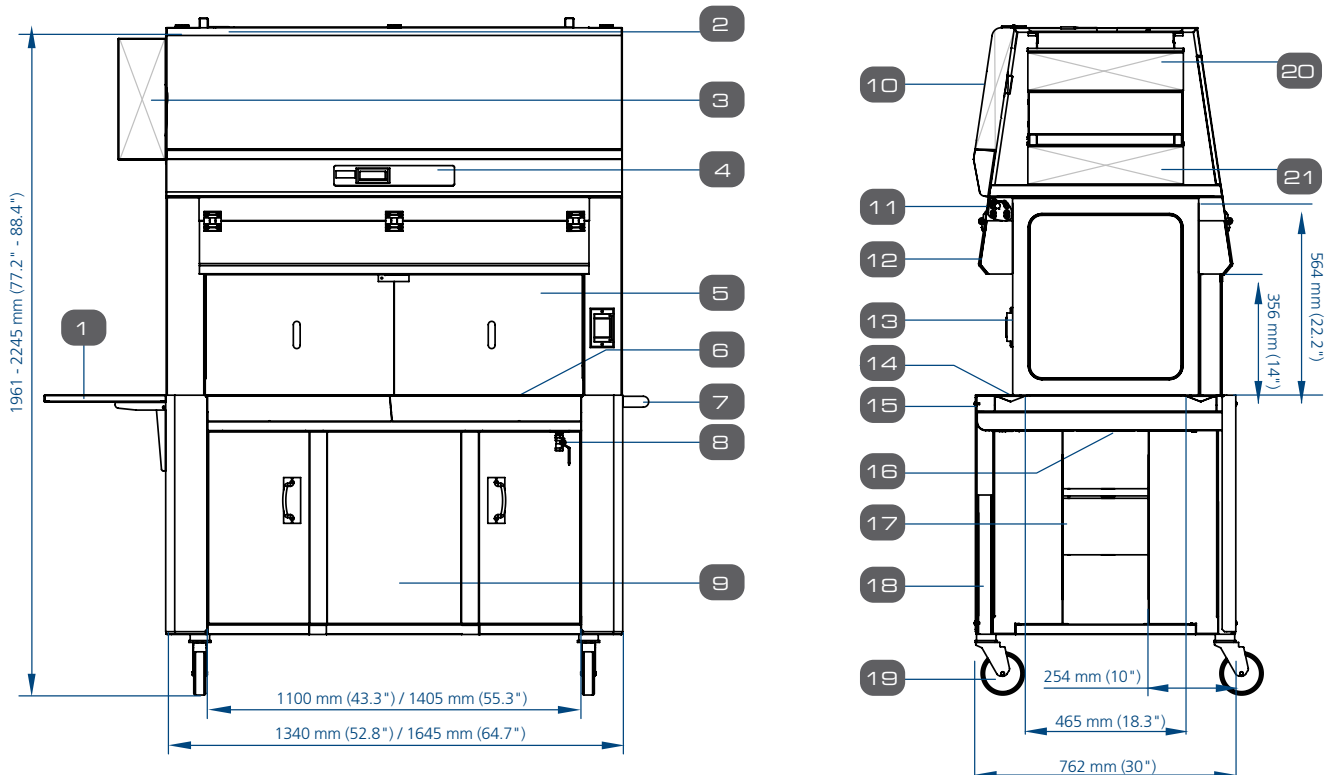

- |  |  |  |
|--|--|--|
| <ul style="list-style-type: none"> <li>1. Foldable Side Tray (Optional)</li> <li>2. Airflow Sensor</li> <li>3. Retractable Cord Reel (30 ft)</li> <li>4. Sentinel™ Gold Microprocessor Control System</li> <li>5. Side Shield (Optional)</li> <li>6. Stainless Steel Work Top</li> <li>7. Push Handle</li> <li>8. Drain Valve</li> </ul> | <ul style="list-style-type: none"> <li>9. Knee Space (254 mm / 10" Deep) at both sides</li> <li>10. Electrical Panel</li> <li>11. LED Lamp (1 on each side)</li> <li>12. Hinged Polycarbonate Window</li> <li>13. Electrical Outlets with Dip Proof Cover (1 on each right side)</li> <li>14. Recessed Air Intake Grill</li> <li>15. Arm Rest</li> </ul> | <ul style="list-style-type: none"> <li>16. Impregnated Activated Carbon Pre-filter</li> <li>17. DC ECM Blower (Self-compensating and Low Noise)</li> <li>18. Electric Hydraulic Height Adjustor</li> <li>19. Caster Wheels</li> <li>20. Exhaust ULPA/H14 Filter</li> <li>21. Downflow ULPA/H14 Filter</li> </ul> |
|--|--|--|

## General Specifications, VIVA® Class II Type A2 Animal BSC

Model	220-240 V 50/60Hz	VA2-4S8 G4 12" 2011861	VA2-5S8 G4 12"* 2011863	VA2-6S8 G4 12" 2011865
	110 - 120 V 50/60Hz	VA2-4S9 G4 12" 2011862	VA2-5S9 G4 12"* 2011864	VA2-6S9 G4 12" 2011866
Nominal Size	1.2 meter (4')		1.5 meter (5')	
External dimensions with SLC support stand at minimum height (W x D x H)**	1485 x 919 x 2025-2533 mm (58.5" x 36.2" x 79.7-99.7")		1790 x 919 x 2025-2533 mm (70.4" x 36.2" x 79.7-99.7")	
Internal work area, dimensions (W x D x H)	1220 x 625 x 720 mm (48.0" x 24.6" x 28.3")		1525 x 625 x 720 mm (60.0" x 24.6" x 28.3")	
Maximum sash opening	575 mm (22.6")			
Average airflow velocity	Inflow	0.53 m/s (105 fpm)		
	Downflow	0.30 m/s (60 fpm)	0.35 m/s (70 fpm)	0.35 m/s (70 fpm)
Airflow volume	Inflow / exhaust without ducting	710 m³/h (420 cfm)	890 m³/h (525 cfm)	1065 m³/h (630 cfm)
	Downflow	771 m³/h (461 cfm)	1128 m³/h (662 cfm)	1349 m³/h (794 cfm)
	Required exhaust with optional thimble exhaust collar	1070 m³/h (630 cfm)	1340 m³/h (790 cfm)	1610 m³/h (950 cfm)
ULPA Filter typical efficiency	>99.999% at 0.1 to 0.3 micron, ULPA as per IEST-RP-CC001.3 USA >99.999% at MPPS, H14 as per EN 1822 EU			
Sound emission per NSF / ANSI 49***	60 dBA	65 dBA	65.9 dBA	
LED Lamp intensity	> 1000 lux (93 foot-candles)			
Cabinet construction	Main body	Electro-galvanized steel with white oven-baked epoxy-polyester Isocide™ antimicrobial powder-coated finish, 1.5 mm (0.06") / 16 gauge thick		
	Workzone	Stainless steel type 304 with no.4 finish, 1.5 mm (0.06") / 16 gauge thick		
Net weight cabinet including stand	287 kg (633 lbs)	381 kg (840 lbs)	400 kg (882 lbs)	
Shipping weight Cabinet including stand	350 kg (772 lbs)	439 kg (968 lbs)	506 kg (1116 lbs)	
Shipping dimensions, maximum (W x D x H) cabinet excluding stand	1400 x 950 x 2250 mm (55.1" x 37.4" x 88.6")	1650 x 950 x 2250 mm (64.9" x 35.0" x 74.8")	2200 x 890 x 1900 mm (86.6" x 35.0" x 74.8")	
Shipping volume, excluding stand	2.5 m³ (cu.ft.)	3.00 m³ (cu.ft.)	3.6 m³ (cu.ft.)	

10

\*Only VA2-4S\_ G4 12" and VA2-6S\_ G4 12" are the NSF-certified models.

\*\*Depth with arm rest removed: 815 mm (32.1") without SLC stand and 852mm (33.5") with SLC stand

\*\*\*Noise as measured in open field / anechoic chamber. Noise reading in normal room varies by room size, layout, and background noise, but may reach roughly 3-4 dBA above these values.

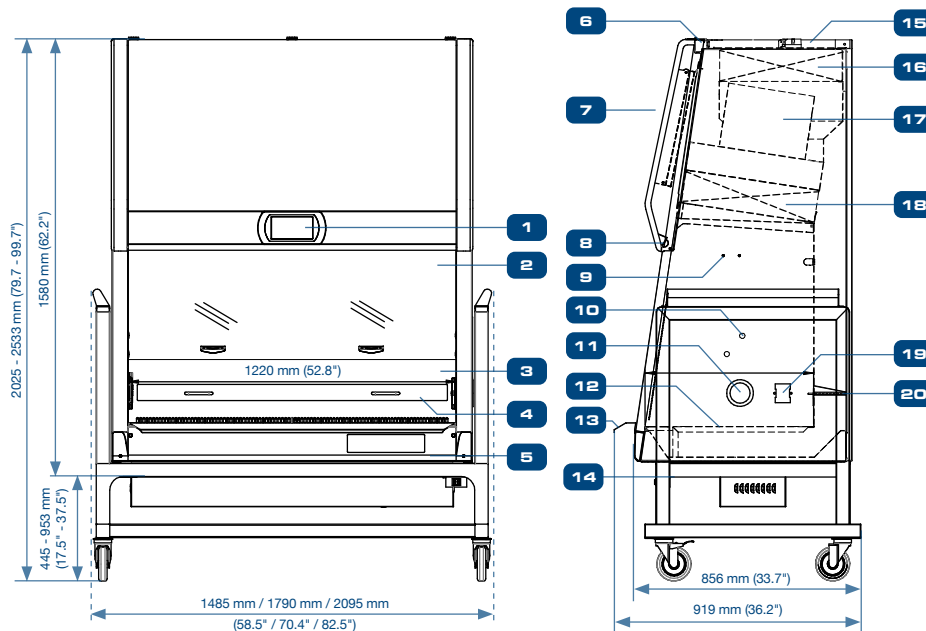

- |  |  |  |                                     |
|--|--|--|-------------------------------------|
| 1. Centurion™ Touchscreen Controller                     | 6. USB Port for Data Transfer Data, Zero Volt Relay Contact (Blower & Alarm) | 11. Cable Port                             | 17. Energy-efficient DC ECM Blower  |
| 2. Safety Glass Sliding Sash Window                      | 7. Electrical Panel  | 12. Stainless Steel Single-piece Work Tray | 18. Downflow ULPA / H14 Filter      |
| 3. Single-piece Stainless Steel Back Wall and Side Walls | 8. LED Lamps   | 13. Stainless Steel Arm Rest               | 19. Pre-filter                      |
| 4. Prefilter Rack  | 9. IV Bar Retrofit Kit Provision   | 14. Drain Valve Retrofit Kit Provision     | 20. GFCI Electrical Outlet (5A Max) |
| 5. Removable Side Panel for Plumbing Access              | 10. Plugged Service Fixture provisions (2 on each side)                      | 15. Airflow Sensor                         |                                     |
|  |  | 16. Exhaust ULPA / H14 Filter              |                                     |

**VIVA.**

Lab Animal Research Products • Animal Containment Workstation

## General Specifications, VIVA Bedding Disposal Workstation, Model VBD-4A\_

Nominal Size		1.2 meter (4')		
External Dimensions (W x D x H)		1247 x 760 x 1966 mm (49.1" x 30.0" x 77.4") minimum height 1247 x 760 x 2271 mm (49.1" x 30.0" x 89.4") maximum height		
Internal Work Area (W x D x H)		1040 x 680 x 594 mm (40.9" x 26.8" x 23.4")		
Work Surface Height		920 mm ~ 1225 mm (36.2" ~ 48.2")		
Front Opening		400 mm (15.7")		
Inflow Velocity		0.35 m/s (70 fpm) at initial setpoint		
Pre-Filter		Disposable, non-washable polyester fiber, 85% arrestance, EU3 rated		
ULPA Filter Typical Efficiency		>99.999% at 0.1 to 0.3 microns as per IEST-RP-CC001.3 USA		
Sound Emission* Per EN 12469		<65 dBA		
LED Lamp		> 1,300 lux (> 121 foot candles)		
Workstation Construction	Main Body	1.2 mm (0.05") 18 gauge electro-galvanized steel with Isocide™ white oven-baked epoxy-polyester powder-coating		
	Work Top	1.2 mm (0.05") 18 gauge stainless steel, type 304, with 4B finish		
	Inner Liner	0.9 mm (0.035") 20 gauge stainless steel, type 304, with 4B finish		
Net Weight		233 Kg (514 lbs)		
Shipping Weight		294 Kg (648 lbs)		
Shipping Dimensions, Maximum (W x D x H)		2150 x 1840 x 1230 mm (84.6" x 72.4" x 48.4")		
Shipping Volume, Maximum		4.87 m <sup>3</sup> (172 cu.ft.)		
Electrical**	Model	VBD-4A1	VBD-4A2	VBD-4A3
	Voltages	220-240 VAC, 50 Hz, 1Φ	110-120 VAC, 60 Hz, 1Φ	220-240 VAC, 60 Hz, 1Φ
	Cabinet Full Load Amps (FLA)	3 A	6.5 A	3 A
	Optional Outlets FLA	5 A	5 A	5 A
	Cabinet Nominal Power	309 W	268 W	309 W
	Cabinet BTU	1054	914	1054

\* Noise as measured in an open field / anechoic chamber.

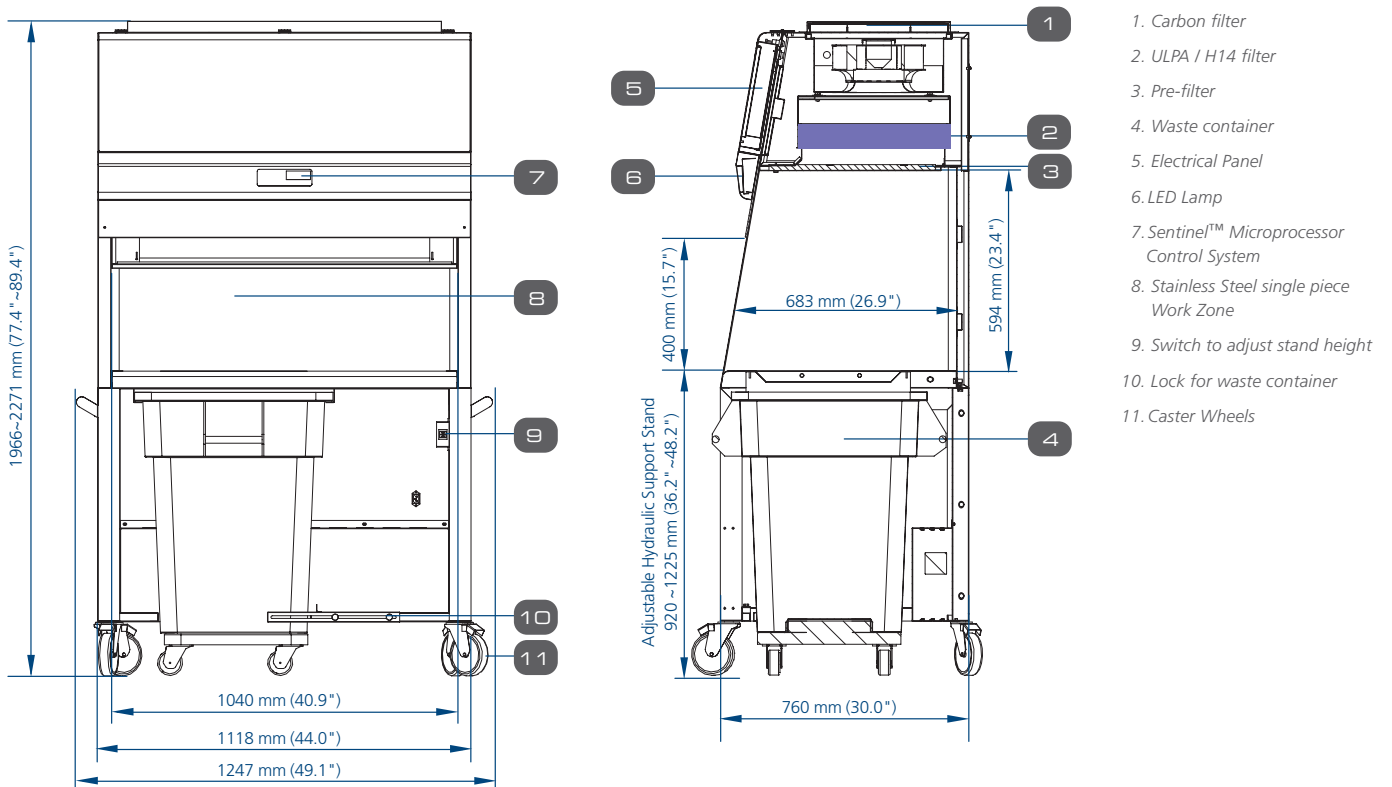

# ESCO LIFESCIENCES GROUP

42 LOCATIONS IN 21 COUNTRIES ALL OVER THE WORLD

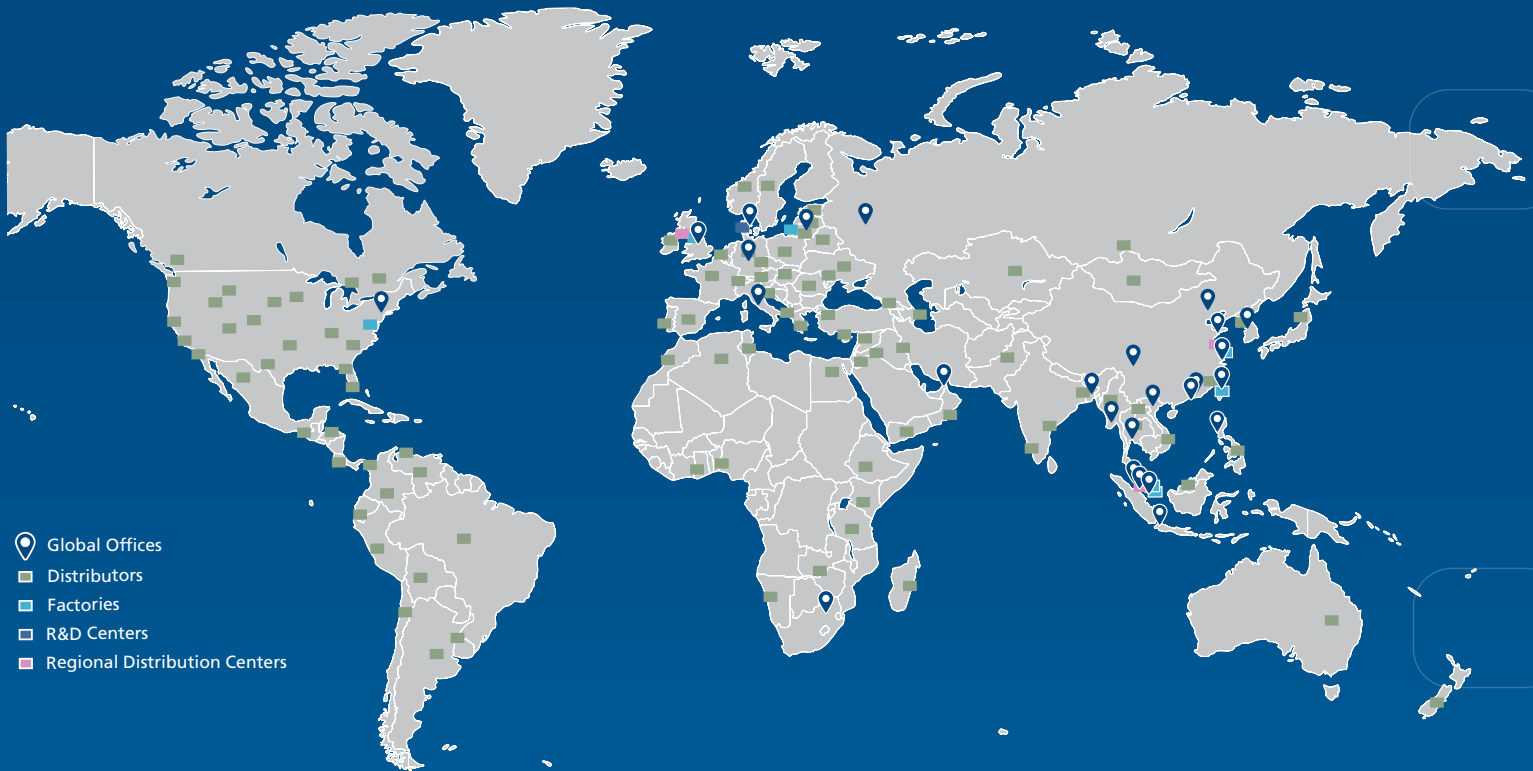

- 📍 Global Offices
- Distributors
- Factories
- R&D Centers
- Regional Distribution Centers

Follow us on social media, download our apps,  
and scan the QR code for more info.



@EscoLifesciences



@EscoLifesciences



@EscoLifesci



@Esco



@EscoLifesciences



@EscoLifesciences



Esco Lifesciences



Esco Lifesciences

# ESCO

LIFESCIENCES GROUP

Esco Micro Pte. Ltd. • 19 Changi South Street 1 • Singapore 486 779

Tel: +65 6542 0833 • mail@escolifesciences.com

www.escolifesciences.com

Esco Technologies, Inc. • 903 Sheehy Drive, Suite F, Horsham, PA 19044, USA

Tel: +1 215-441-9661 • Fax 484-698-7757

eti.admin@escolifesciences.com

Esco Lifesciences Group Offices: Bangladesh | China | Denmark | Germany | Hong Kong | India | Indonesia | Italy | Japan | Lithuania | Malaysia | Myanmar | Philippines | Russia | Singapore | South Africa | South Korea | Taiwan | Thailand | UAE | UK | USA | Vietnam